

Conbextra GP

General purpose non – shrink cementitious grout

Uses

Conbextra GP is used for general purpose grouting where it is essential to eliminate shrinkage when completely filling the void between a base plate and a substrate. Such an application would be the grouting of a stanchion base plate. It can also be used for anchoring a wide range of fixings including starter bars, masts and anchor bolts.

Conbextra GP can also be used as a patch repair material for minor concrete defects in new construction.

Advantages

- Gaseous expansion system compensates for shrinkage and settlement in the plastic state.
- No metallic iron content to cause staining.
- Prepackaged material overcomes potential on-site batching variations.
- Develops high early strength without the use of chlorides.
- High ultimate strength and low permeability ensure the durability of the hardened grout.



Description

Conbextra GP general purpose non-shrink cementitious grout is supplied as a ready to use dry powder. The addition of a controlled amount of clean water produces a flowing non-shrink grout for gap thicknesses up to 100 mm.

Conbextra GP is a blend of Portland cement, graded fillers and chemical additives which impart controlled expansion in the plastic state whilst minimizing water demand. The low water demand ensures high early strength. The graded filler is designed to assist uniform mixing and produce a consistent grout.

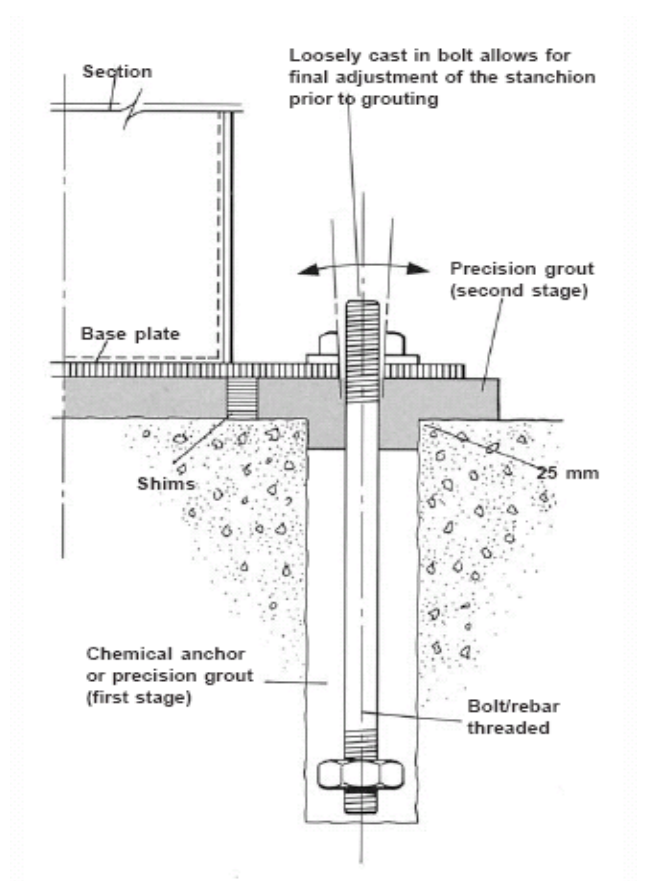

Technical support

Fosroc offers comprehensive range of high quality, high performance construction products. In addition, Fosroc offers a world wide technical support and on-site service to specifiers, end- users and contractors.

Conbextra GP

Typical Properties

The following typical results were obtained at a water : powder ratio of 0.18 and temperature of 20°C.

Test method for	Typical result
Compressive strength	26 N/mm ² @ 1 day
BS 1881: part 116 1983:	55 N/mm ² @ 7 days >70 N/mm ² @ 28 days
Flexural strength	2.5 N/mm ² @ 1 day
BS 4551 1980:	9.0 N/mm ² @ 7 days 10.0N/mm ² @ 28 days
Time for expansion	
Start:	15 minutes
Finish:	2 hours
Fresh wet density:	Approximately 2170kg/m ³ depending on actual consistency used.
Young's modulus	
ASTM 469-83:	28 kN/mm ²
Expansion characteristics:	An expansion of up to 1%overcomes plastic settlement in the unset material.

Specification clauses

Performance specification

All grouting where shown on the drawing must be carried out with a pre-packaged cement based product which is chloride-free.

It shall be mixed with clean water to the required consistency. The plastic grout must not bleed or segregate.

A positive volumetric expansion shall occur while the grout is plastic by means of a gaseous system.

The compressive strength of the grout must exceed 40 N/mm² at 7 days and 60 N/mm² at 28 days.

The storage, handling and placement of the grout must be in strict accordance with the current datasheet.

Supplier specification

All grouting where shown on the drawing must be carried out using Conbextra GP manufactured by Fosroc and used in accordance with the manufacturer's current data sheet.

Application instructions

Preparation

Foundation surface

The substrate surface must be free from oil, grease or any loosely adherent material. If the concrete surface is defective or has laitance, it must be cut back to a sound base. Bolt holes and fixing pockets must be blown clean of any dirt or debris.

Pre-soaking

Several hours prior to grouting the area of cleaned foundation should be flooded with fresh water. Immediately before grouting takes place any free water should be removed with particular care being taken to blow out all bolt holes and pockets.

Base plate

It is essential that this is clean and free from oil, grease or scale. Air pressure relief holes should be provided to allow venting of any isolated high spots.

Levelling shims

If these are to be removed after the grout has hardened, they should be treated with a thin layer of grease.

Formwork

The formwork should be constructed to be leakproof. This can be achieved by using foam rubber strip or mastic sealant beneath the constructed formwork and between joints.

In some cases it is practical to use a sacrificial semi-dry sand and cement formwork. The formwork should include outlets for pre-soaking.

Unrestrained surface area

This must be kept to a minimum. Generally the gap width between the perimeter formwork and the plate edge should not exceed 150 mm on the pouring side and 50

Conbextra GP

mm on the opposite side. It is advisable where practical to have no gap at the flank sides.

Mixing and placing

Mixing

For best results a mechanically powered grout mixer should be used. When quantities up to 50 kg are used, a slow speed (400-500 rpm), heavy duty drill fitted with a high shear “Conbextra” type mixing paddle is suitable. In order to ensure adequate mixing, a minimum drill capacity of 1kW is required. Larger quantities will require a high shear vane mixer. Do not use a colloidal impeller mixer.

To enable the grouting operation to be carried out continuously, it is essential that sufficient mixing capacity and labour are available. The use of a grout holding tank with provision to gently agitate the grout may be required.

Consistency of grout mix

The quantity of clean water required to be added to a 25 kg bag to achieve the desired consistency is given below.

Trowellable: 3.4 - 3.6 litres

Flowable: 4.0 - 4.5 litres

The selected water content should be accurately measured into the mixer. The total contents of the Conbextra GP bag should be slowly added and continuous mixing should take place for 5 minutes. This will ensure that the grout has a smooth even consistency.

Grout Consistency	Gap Width mm	max. flow distance in mm		
		50mm head	100mm head	250mm head
Flowable	20	200	950	1600
	30	350	1500	2300
	40	600	2200	3000
	50	900	3000	3000+

N.B: This table is based on the following factors.

Temperature 20oC

Minimum gap width 20mm

Water saturated substrate

Minimum unrestricted flow width 300mm.

Placing

At 20°C place the grout within 20 minutes of mixing to gain full benefit of the expansion process.

Conbextra GP can be placed in thicknesses up to 100 mm in a single pour when used as an underplate grout. For thicker sections it is necessary to fill out Conbextra GP with well graded silt free aggregate to minimise heat build up. Typically a 10 mm aggregate is suitable.

Any bolt pockets must be grouted prior to grouting between the substrate and the base plate.

Continuous grout flow is essential. Sufficient grout must be prepared before starting. The time taken to pour a batch must be regulated to the time to prepare the next one.

Typical hopper system

Removable hopper: For larger pours the grout may be hand placed or pumped into a removable hopper (trough).

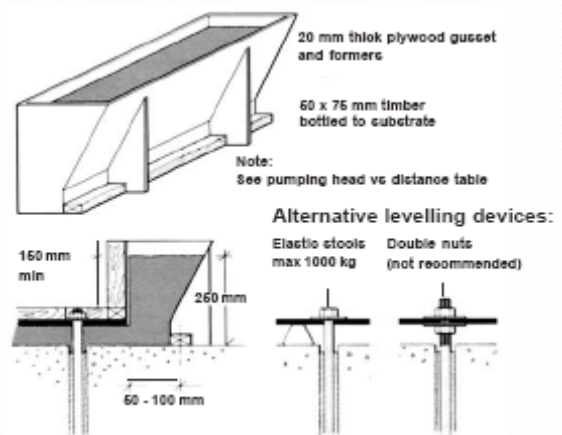

Pouring should be from one side of the void to eliminate any air or pre-soaking water becoming trapped under the baseplate. It is advisable to pour the grout across the shortest distance of travel. The grout head must be maintained at all times so that a continuous grout front is achieved.

Where large volumes have to be placed Conbextra GP may be pumped. A heavy duty diaphragm pump is recommended for this purpose. Screw feed and piston pumps may also be suitable.

Curing

On completion of the grouting operation, exposed areas should be thoroughly cured. This should be done by the use of Concure curing membrane, continuous application of water and/or wet hessian.

Conbextra GP

Cleaning

Conbextra GP should be removed from tools and equipment with clean water immediately after use. Cured material can be removed mechanically.

Limitations

Low temperature working

When the air or contact surface temperatures are 5°C or below on a falling thermometer, warm water (30-40°C) is recommended to accelerate strength development.

For ambient temperatures below 10°C the formwork should be kept in place for at least 36 hours.

Normal precautions for winter working with cementitious materials should then be adopted.

High temperature working

At ambient temperatures above 35°C cool water (below 20°C) should be used for mixing the grout prior to placement.

Estimating

Supply

Conbextra GP is supplied in 25 kg moisture resistant bags.

Note: In accordance with Commercial or Health & Safety requirements packaging detail may alter. Please contact your local Fosroc office for detail.

Yield

Allowance should be made for wastage when estimating quantities required. The approximate yield per 25 kg bag for different consistencies is:

Consistency	Trowellable	Flowable
Yield (litres):	12	13.25

Storage

Conbextra GP has a shelf life of 9 months if kept in a dry store in the original, unopened bags.

Precautions

Health and safety

Conbextra GP is alkaline and should not come into contact with skin and eyes. Avoid inhalation of dust during mixing.

Gloves, goggles and dust mask should be worn.

If contact with skin occurs, wash with water. Splashes to eyes should be washed immediately with plenty of clean water and medical advice sought.

For further information, refer to the product Material Safety Data Sheet.

Fire

Conbextra GP is non-flammable.

Conbextra is the trademark of Fosroc International Limited



Important note

Fosroc products are guaranteed against defective materials and manufacture and are sold subject to its standard Conditions for the Supply of Goods and Services, copies of which may be obtained on request. Whilst Fosroc endeavours to ensure that any advice, recommendation, specification of information it may give is accurate and correct, it cannot, because it has no direct or continuous control over where or how its products are applied, accept any liability either directly or indirectly arising from the use of its products, whether or not in accordance with any advice, specification, recommendation of information given by it.

Fosroc Singapore

30 Toh Guan Road
#07-07, ODC District Centre
Singapore 608840

telephone:
+ 65 6665 3828

fax:
+ 65 6899 1283

email:
Fosroc.Singapore@Fosroc.com

www.fosroc.com